



SERIES H

HEAD X

H365X

H440X

H500X

HEAD V

H340V

H455V

HEAD A

H455A

H630A

H685A

GB

M029147CA

Rev. 0.0

08-2025

LET'S LIGHT UP THE FUTURE.

CIB Unigas was founded in 1972 as a small company by Mr. Claudio Pancolini. The remarkable creative and design skills of its technical staff enabled the company to penetrate the market quickly and effectively. Over the past 50 years, with the goal of promoting eco-sustainable fuels and applications, **CIB Unigas has become one of the leading companies in the design, production and sale of burners for civil and industrial applications.**

Factors such as the progressive shift in demand abroad (over 85% of current turnover) and the willingness to develop a solid distribution network, have allowed the company to **open numerous branches, particularly in the United Kingdom, China, and the United States, in addition to more than 60 official dealers worldwide.** This strengthened and widespread sales network, combined with the complete range of burners offered and the constant participation in international conferences and trade fairs, has made CIB Unigas a leader in its sector.

In 1994, CIB Unigas obtained ISO 9001 quality certification and product certification (CE marking), issued by the most authoritative European certification body (TÜV). This certification is the most comprehensive available in this industrial sector, covering design, production, marketing, and after-sales services. As a result, the company currently meets all national and international requirements to sell, market, and install its products worldwide.

Today, the company is managed by the founder's heirs Mr. Filippo Pancolini and Mr. Riccardo Pancolini, who ensure the continuity not only of the business but also of CIB Unigas' vision: developing technologies with the aim of protect our world and our future. **With over 200 employees, the company produces all its products at its Italian plant facility in Campodarsego (Padua), where its main activities of design, assembly and innovation take place.**

Thanks to the strong flexibility of its production and organizational structure, CIB Unigas is able to meet any demand quickly and according to the specific requirements that arise from the market. This means, not only the ability to produce in series, but above all, the creative strength to satisfy market demands—values that are at the core of the shared efforts at CIB Unigas.



SERIES H

LOW NOx

Low emissions (Class 3 - EN676)

Possibility of working with innovative fuels with low environmental impact, such as hydrogen

Wide modulation range

HEAD X

H365X / H440X / H500X	GAS	7
H365X / H440X / H500X	GAS / LIGHT OIL	11

ULTRA LOW NOx

Low emissions (Class 4 - EN676)

Wide modulation range

HEAD V

H340V / H455V	GAS	15
---------------	-----	----

High flexibility burners

Extensive flexibility

Adjustment flexibility

Ability to work with a variety of fuels

Many types of civil and industrial applications

Special applications and furnaces

HEAD A

H455A / H630A / H685A	GAS	15
H455A / H630A / H685A	GAS / LIGHT OIL	19

DESIGNATION

M-. PR. SR. xx. A. 1. 50. EA. xxx.

FUEL

- M - NATURAL GAS
- L - L.P.G.
- B - BIOGAS
- C - TOWN GAS
- G - LIGHT OIL
- A - BIO DIESEL
- K - KEROSENE
- N - HEAVY OIL UP TO 50 cSt at 50°C (7°E - 50°C)
- D - HEAVY OIL UP TO 400 cSt at 50°C (50°E - 50°C)

* VARIOUS FUEL CONFIGURATIONS AVAILABLE IN THE DUAL-FUEL VERSION

OPERATION

- PR - PROGRESSIVE
- MD - FULLY MODULATING

BLAST TUBE

- | | |
|-------------------------------------|--|
| S - STANDARD | SP - Standard blast tube + ABS polymer (silenced) air intake |
| M - STANDARD DUAL LENGTH BLAST TUBE | SR - Standard blast tube + ABS polymer (silenced) air intake |
| L - LONG | LP - Extended blast tube + aluminum air intake |
| | LR - Extended blast tube + ABS polymer (silenced) air intake |

DESTINATION COUNTRY

- GB - UNITED KINGDOM
- ... AVAILABLE FOR OTHER COUNTRIES UPON REQUEST

BURNER MANUFACTURE

- | | |
|------------|----------------------------------|
| A STANDARD | G CONTROL PANEL AND JUNCTION BOX |
| Y SPECIAL | E JUNCTION BOX |

EQUIPMENT

- 0 2 GAS VALVES
- 1 2 GAS VALVES + LEAKAGE CONTROL
- 7 2 GAS VALVES + MAXIMUM GAS PRESSURE SWITCH
- 8 2 GAS VALVES + LEAKAGE CONTROL AND MAXIMUM GAS PRESSURE SWITCH

GAS CONNECTION

- | | |
|---------|-----------|
| 50 DN50 | 80 DN80 |
| 65 DN65 | 100 DN100 |
| | 125 DN125 |

ELECTRONIC VERSION

- EA Burners complete with electronic cam
- EB Burners complete with electronic cam and inverter
- EC Dual fuel burners complete with electronic cam
- ED Dual fuel burners complete with electronic cam and inverter
- ES Burners complete with electronic cam, without O₂ control, without inverter
- EO Burners complete with electronic cam and O₂ control, without inverter
- EI Burners complete with electronic cam and inverter, without O₂ control
- EK Burners complete with electronic cam with O₂ control and with inverter
- EF Burners complete with electronic cam and temperature-compensated flue gas recirculation FGR without O₂ monitoring, without inverter
- EG Burners complete with electronic cam, inverter and temperature-compensated flue gas recirculation FGR without O₂ monitoring
- EP Burners complete with electronic cam and temperature-compensated flue gas recirculation FGR with O₂ monitoring, without inverter
- ER Burners complete with electronic cam, inverter and temperature-compensated flue gas recirculation FGR with O₂ monitoring

FLUE GAS RECIRCULATION

- FGR Flue gas recirculation

SOME FEATURES ARE NOT INCLUDED IN THIS CATALOGUE

FOR CONFIGURATIONS OF BURNERS IN THE LAMTEC VERSION WITH O₂ + CO OXYGEN CONTROL, PLEASE CONTACT OUR SALES DEPARTMENT.

HEAD X

H365X

H440X

H500X

Low NOx

Low emissions (Class 3 - EN676)

Possibility of working with innovative fuels with low environmental impact such as hydrogen

Wide modulation range

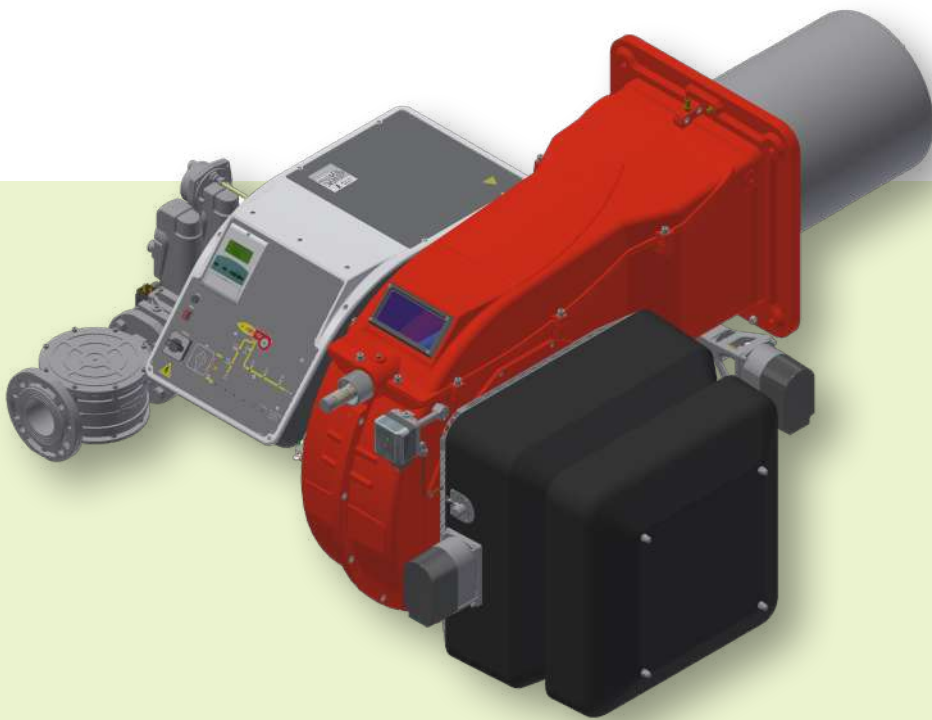

GAS

TECHNICAL SPECIFICATIONS

Type	Model	Power kW		Power supply single-phase electricity auxiliary	Power supply three-phase electric motor	Fan motor kW	Gas connections	Level of noise emissions dBA
		min	max					
H365X	M-.xx.xR.IT.A.1.xxx	650	3.650	230 V 1N AC 50 Hz	400 V 3 AC 50 Hz	7,5	2" - DN65 - DN80 - DN100	< 85
H440X	M-.xx.xR.IT.A.1.xxx	700	4.400	230 V 1N AC 50 Hz	400 V 3 AC 50 Hz	9,2	2" - DN65 - DN80 - DN100	< 85
H500X	M-.xx.xR.IT.A.1.xxx	580	5.250	230 V 1N AC 50 Hz	400 V 3 AC 50 Hz	9,2	2" - DN65 - DN80 - DN100	< 85

For information on choosing the length of the blast tube, refer to the Technical Information booklet.

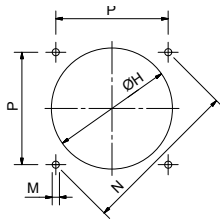
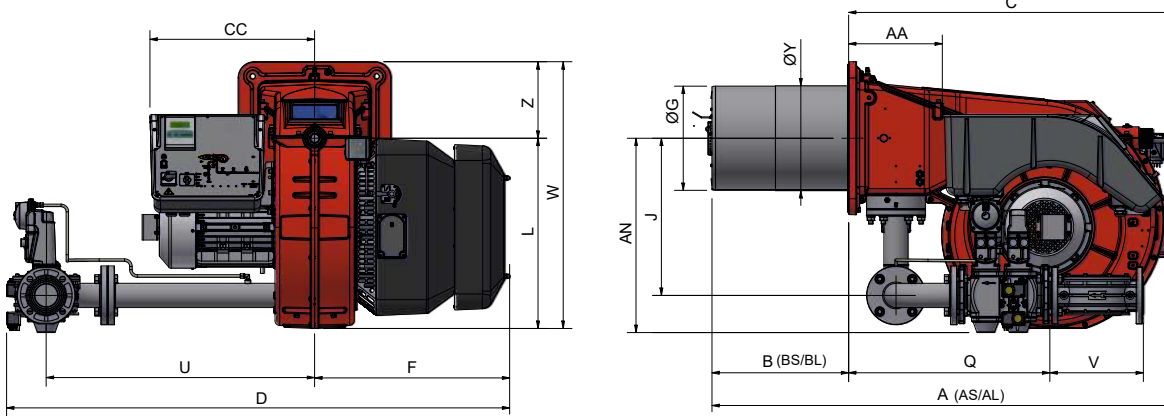

BOILER RECOMMENDED DRILLING TEMPLATE

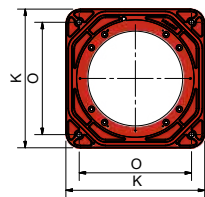

BURNER FLANGE



PACKAGING DIMENSIONS* (mm)

Type	l	p	h	kg
H365X	1890	1290	1220	315
H440X	1890	1290	1220	335
H500X	1890	1290	1220	350

***INDICATIVE VALUES**

DIMENSIONS* (mm)

Type	Model	Overall dimensions																					
		AA	AN	B BS	BL	C	CC	D	F	G	H	J	K	L	M	N	O	P	Q	U	V	W	Y
H365X	M-.xx.xR.IT.A.1.50	295	595	430	530	1220	528	1554	504	284	316	494	482	598	M14	552	390	390	771	845	190	839	286
H365X	M-.xx.xR.IT.A.1.65	295	611	430	530	1220	528	1577	504	284	316	494	482	598	M14	552	390	390	634	845	294	839	286
H365X	M-.xx.xR.IT.A.1.80	295	626	430	530	1220	528	1610	504	284	316	494	482	598	M14	552	390	390	686	875	313	839	286
H365X	M-.xx.xR.IT.A.1.100	295	639	430	530	1220	528	1690	504	284	316	494	482	598	M14	552	390	390	791	942	353	839	286
H440X	M-.xx.xR.IT.A.1.50	295	595	430	530	1220	528	1554	610	328	370	494	482	598	M14	552	390	390	771	845	190	839	330
H440X	M-.xx.xR.IT.A.1.65	295	611	430	530	1220	528	1577	610	328	370	494	482	598	M14	552	390	390	634	845	294	839	330
H440X	M-.xx.xR.IT.A.1.80	295	626	430	530	1220	528	1610	610	328	370	494	482	598	M14	552	390	390	686	875	313	839	330
H440X	M-.xx.xR.IT.A.1.100	295	639	430	530	1220	528	1690	610	328	370	494	482	598	M14	552	390	390	791	942	353	839	330
H500X	M-.xx.xR.IT.A.1.50	295	595	430	530	1017	528	1561	610	360	400	494	482	598	M14	552	390	390	771	845	190	839	356
H500X	M-.xx.xR.IT.A.1.65	295	611	430	530	1017	528	1584	610	360	400	494	482	598	M14	552	390	390	634	845	294	839	356
H500X	M-.xx.xR.IT.A.1.80	295	626	430	530	1017	528	1617	610	360	400	494	482	598	M14	552	390	390	686	875	313	839	356
H500X	M-.xx.xR.IT.A.1.100	295	639	430	530	1017	528	1617	610	360	400	494	482	598	M14	552	390	390	791	942	353	839	356

***INDICATIVE VALUES**

Attention: - The size of the gas train varies according to size and configuration.

ELECTRONIC OPERATION

Model	Gas train	Operation
M-.PR.SR.IT.A.1.50.EA	2"	PR (*)
M-.PR.SR.IT.A.1.65.EA	DN65	PR (*)
M-.PR.SR.IT.A.1.80.EA	DN80	PR (*)
M-.PR.SR.IT.A.1.100.EA	DN100	PR (*)
M-.MD.SR.IT.A.1.50.ES	2"	MD
M-.MD.SR.IT.A.1.65.ES	DN65	MD
M-.MD.SR.IT.A.1.80.ES	DN80	MD
M-.MD.SR.IT.A.1.100.ES	DN100	MD

SP = Standard blast tube + aluminum air intake (1)
 SR = Standard blast tube + ABS polymer (silenced) air intake
 LP = Extended blast tube + aluminum air intake
 LR = Extended blast tube + ABS polymer (silenced) air intake (2)
 PR = Progressive Adjustment
 MD (*) = Modulating adjustment
 (for the MD modulating version, the Modulation Kit must be added; see the list of variants)

Modulation kit = Kit to be combined with PR Progressive versions

In the MD modulating version, the burner must be equipped with the relevant modulating probe to complete the supply.

For LPG burners, see the list of variants

(1) For applications on furnaces and rotary drums, see the version with aluminium drawer (SP). Contact Cib Unigas for any clarification.

(2) For the following versions, please contact our offices.

The products comply with European standards EN676 and EN267 and the following directives:
 DIRECTIVE GAR 2016/426/EU

NOx emission level:
 - Class 3 (<80 mg/kWh) in gas operation according to EN676

For information on choosing the length of the blast tube, refer to the Technical Information booklet.



Burners also compatible with GPL, H₂

PERFORMANCE CURVES

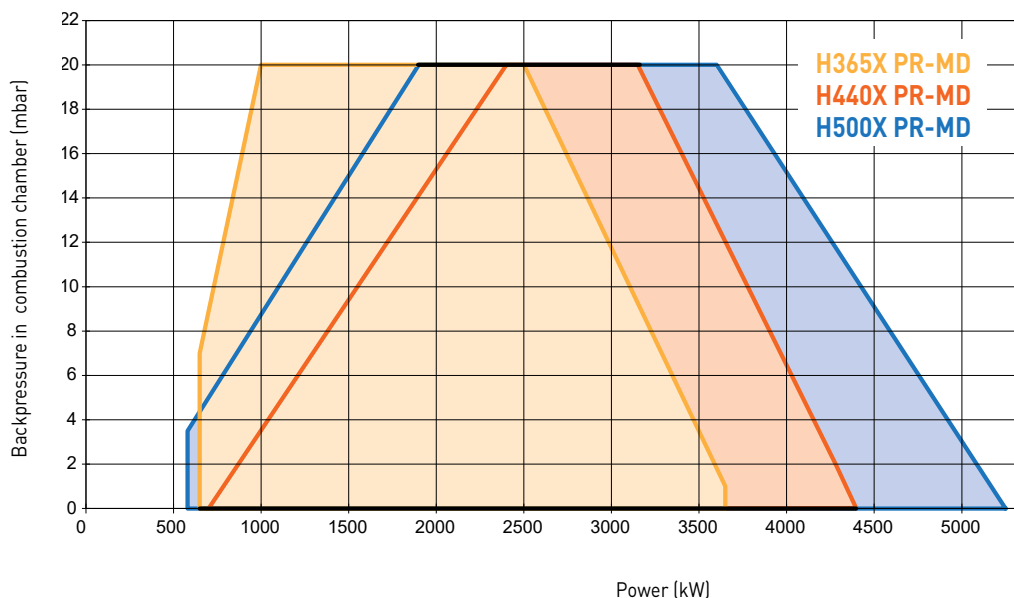

PERFORMANCE CURVES

PRESSURE IN THE NETWORK

H365X PR-MD

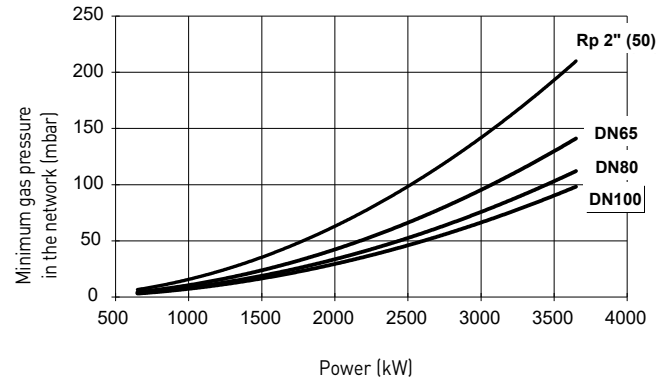
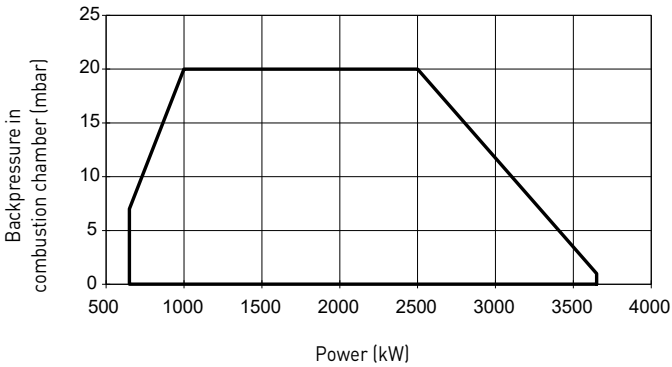

H440X PR-MD

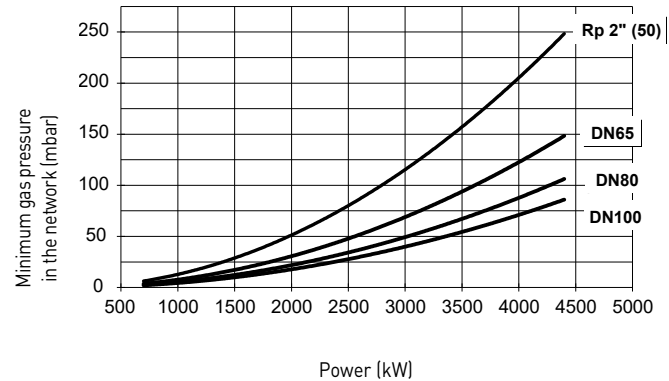
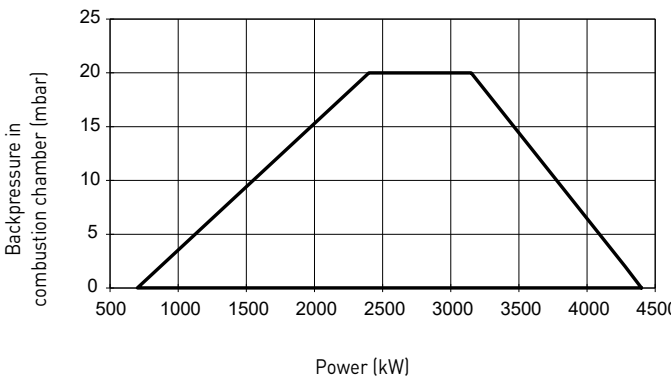

H500X PR-MD

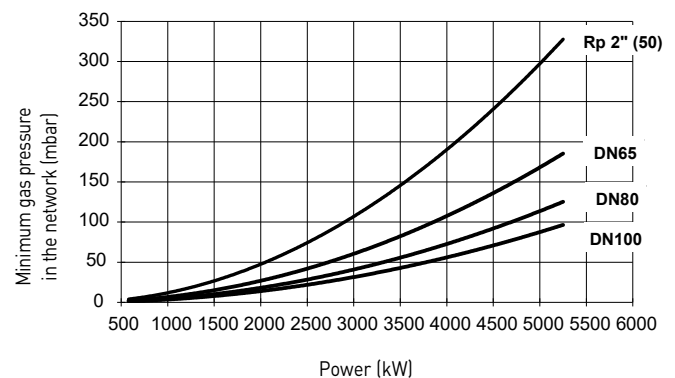
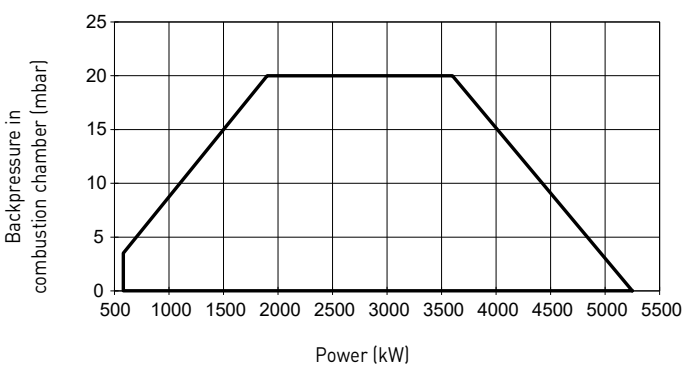

Attention:

- The working range values were determined with reference to laboratory tests with natural gas of lower calorific value $Hi=34.02 \text{ MJ/Stm}^3$ and density 0.714 kg/Stm^3 , (Stm^3 refers to 1013 mbar and 15° C) and ambient conditions 1013 mbar and 20° C .
- To know the minimum gas pressure in the network, it is necessary to add the boiler back pressure to the value read on the curve.
- The pressure values vary depending on the configuration of the gas ramp. The minimum gas pressure curves refer to gas ramps assembled with standard supply valves.
- In the abscissa is the power value, in the ordinate the corresponding network pressure value net of the pressure in the combustion chamber. In order to know the minimum pressure at the ramp inlet, necessary to obtain the required gas flow, the pressure in the combustion chamber must be added to the value read on the ordinate.

Low NOx

HEAD X

H365X

H440X

H500X

- Low emissions (Class 3 - EN676)
- Possibility of working with innovative combustibles with low environmental impact such as
- Ample modulation range

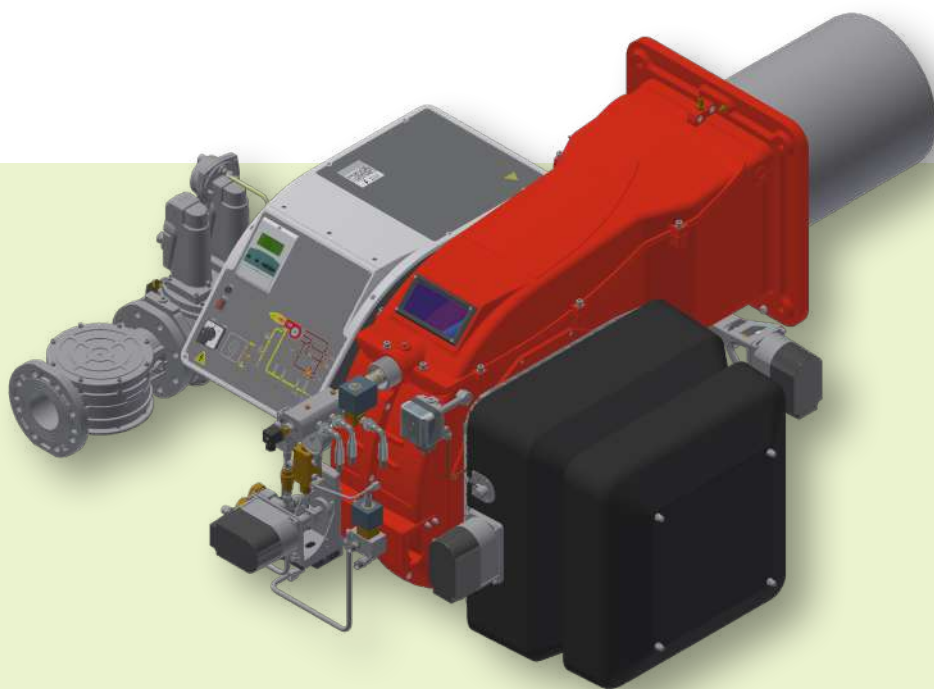

GAS / LIGHT OIL

TECHNICAL SPECIFICATIONS

Type	Model	Power kW		Power supply single-phase electricity auxiliary	Power supply three-phase electric motor	Fan motor kW	Pump motor kW	Gas connections	Level of noise emissions dBA
		min	max						
H365X	MG.xx.xR.IT.A.1.xxx	650	3.650	230 V 1N AC 50 Hz	400 V 3 AC 50 Hz	7,5	1,1	2" - DN65 - DN80 - DN100	< 85
H440X	MG.xx.xR.IT.A.1.xxx	700	4.400	230 V 1N AC 50 Hz	400 V 3 AC 50 Hz	9,2	1,5	2" - DN65 - DN80 - DN100	< 85
H500X	MG.xx.xR.IT.A.1.xxx	580	5.250	230 V 1N AC 50 Hz	400 V 3 AC 50 Hz	9,2	1,5	2" - DN65 - DN80 - DN100	< 85

For information on choosing the length of the blast tube, refer to the Technical Information booklet.

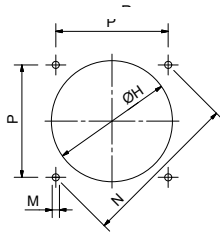
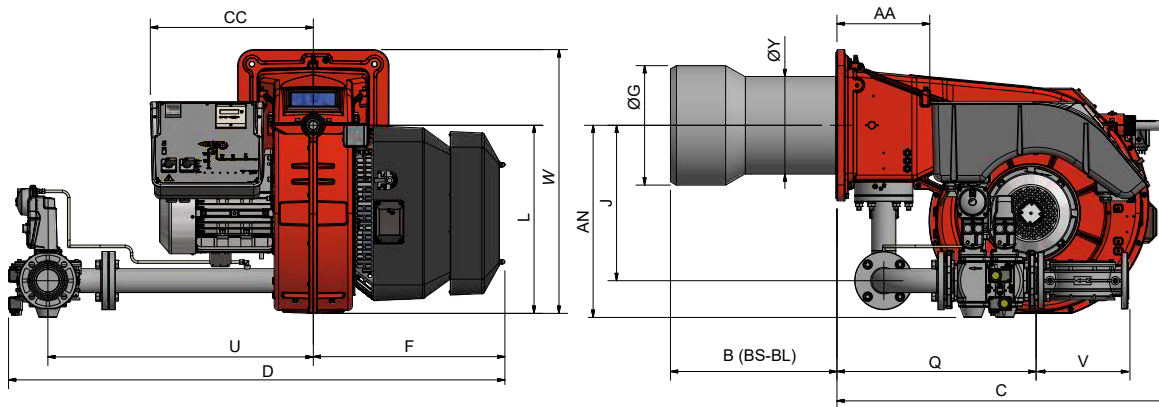

BOILER RECOMMENDED DRILLING TEMPLATE

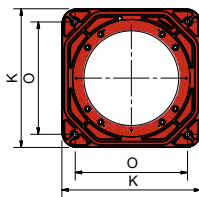

BURNER FLANGE

PACKAGING DIMENSIONS* (mm)

Type	l	p	h	kg
H365X	1890	1290	1220	360
H440X	1890	1290	1220	410
H500X	1890	1290	1220	415

***INDICATIVE VALUES**

DIMENSIONS* (mm)

Type	Model	Overall dimensions																					
		AA	AN	B BS	C BL	CC	D	F	G	H	J	K	L	M	N	O	P	Q	U	V	W	Y	
H365X	MG.xx.xR.IT.A.1.50	295	595	430	530	1232	528	1554	504	284	316	494	482	586	M14	552	390	390	771	845	190	839	286
H365X	MG.xx.xR.IT.A.1.65	295	611	430	530	1232	528	1577	504	284	316	494	482	586	M14	552	390	390	634	845	294	839	286
H365X	MG.xx.xR.IT.A.1.80	295	626	430	530	1232	528	1610	504	284	316	494	482	586	M14	552	390	390	686	875	313	839	286
H365X	MG.xx.xR.IT.A.1.100	295	639	430	530	1232	528	1690	504	284	316	494	482	586	M14	552	390	390	791	942	353	839	286
H440X	MG.xx.xR.IT.A.1.50	295	595	430	530	1232	528	1554	614	328	370	494	482	586	M14	552	390	390	771	845	190	839	330
H440X	MG.xx.xR.IT.A.1.65	295	611	430	530	1232	528	1577	614	328	370	494	482	586	M14	552	390	390	634	845	294	839	330
H440X	MG.xx.xR.IT.A.1.80	295	626	430	530	1232	528	1610	614	328	370	494	482	586	M14	552	390	390	686	875	313	839	330
H440X	MG.xx.xR.IT.A.1.100	295	639	430	530	1232	528	1690	614	328	370	494	482	586	M14	552	390	390	791	942	353	839	330
H500X	MG.xx.xR.IT.A.1.50	295	595	430	530	1232	528	1554	614	360	400	494	482	586	M14	552	390	390	771	845	190	839	356
H500X	MG.xx.xR.IT.A.1.65	295	611	430	530	1232	528	1577	614	360	400	494	482	586	M14	552	390	390	634	845	294	839	356
H500X	MG.xx.xR.IT.A.1.80	295	626	430	530	1232	528	1610	614	360	400	494	482	586	M14	552	390	390	686	875	313	839	356
H500X	MG.xx.xR.IT.A.1.100	295	639	430	530	1232	528	1690	614	360	400	494	482	586	M14	552	390	390	791	942	353	839	356

***INDICATIVE VALUES**

Attention: - The size of the gas train varies according to size and configuration.

REGOLAZIONE ELETTRONICA

Model	Gas train	Operation
MG.PR.SR.IT.A.1.50.EC	2"	PR (*)
MG.PR.SR.IT.A.1.65.EC	DN65	PR (*)
MG.PR.SR.IT.A.1.80.EC	DN80	PR (*)
MG.PR.SR.IT.A.1.100.EC	DN100	PR (*)
MG.MD.SR.IT.A.1.50.ES	2"	MD
MG.MD.SR.IT.A.1.65.ES	DN65	MD
MG.MD.SR.IT.A.1.80.ES	DN80	MD
MG.MD.SR.IT.A.1.100.ES	DN100	MD

SP = Standard blast tube + aluminum air intake (1)
 SR = Standard blast tube + ABS polymer (silenced) air intake
 LP = Extended blast tube + aluminum air intake
 LR = Extended blast tube + ABS polymer (silenced) air intake (2)
 PR = Progressive Adjustment
 MD (*) = Modulating adjustment
 (for the MD modulating version, the Modulation Kit must be added; see the list of variants)

Modulation kit = Kit to be combined with PR Progressive versions

In the MD modulating version, the burner must be equipped with the relevant modulating probe to complete the supply.

For LPG burners, see the list of variants

(1) For applications on furnaces and rotary drums, see the version with aluminium drawer (SP). Contact Cib Unigas for any clarification.

(2) For the following versions, please contact our offices.

The products comply with European standards EN676 and EN267 and the following directives:
 DIRECTIVE GAR 2016/426/EU
 DIRECTIVE Low Tension 2014/35/UE
 DIRECTIVE Electromagnetic compatibility 2014/30/UE
 DIRECTIVE Machinery 2006/42/CE

NOx emission level:

- Class 3 (<80 mg/kWh) in gas operation according to EN676
- Class 2 (< 185 mg/kWh) in light oil operation according to EN267

For information on choosing the length of the blast tube, refer to the Technical Information booklet.



Burners also compatible with GPL, H₂
 Burners also compatible with bio-oli

PERFORMANCE CURVES

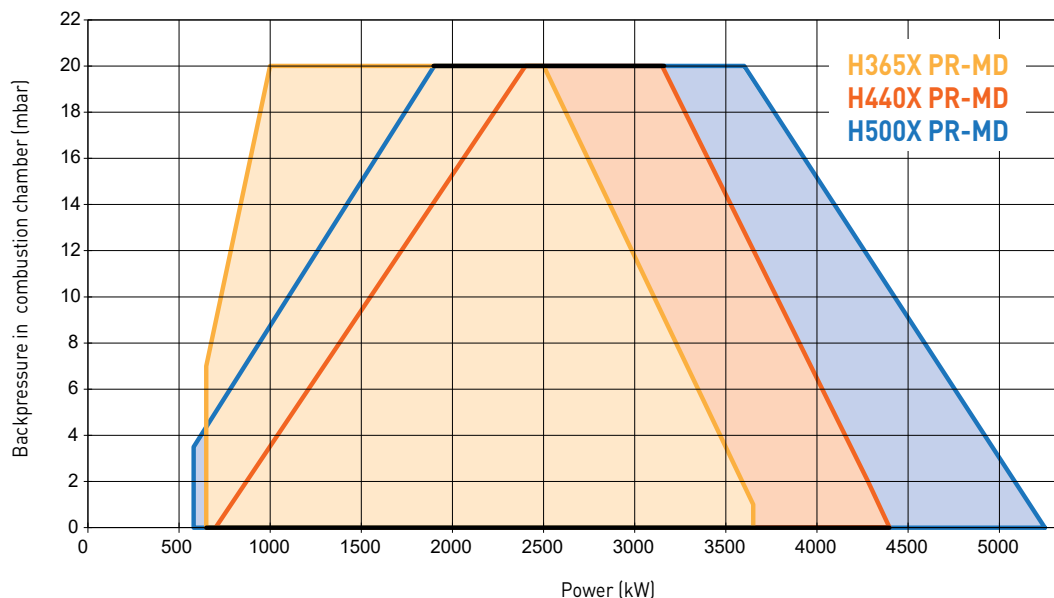

PERFORMANCE CURVES

PRESSURE IN THE NETWORK

H365X PR-MD

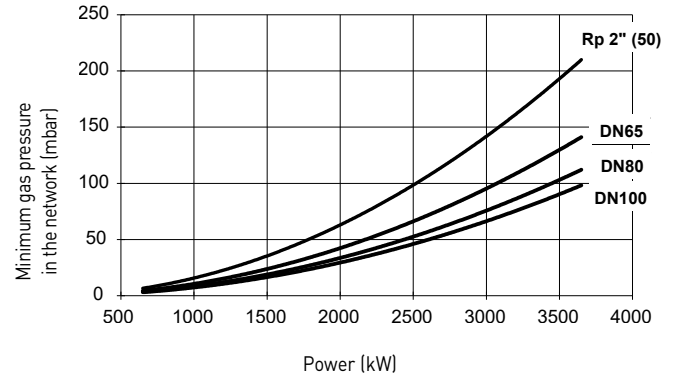
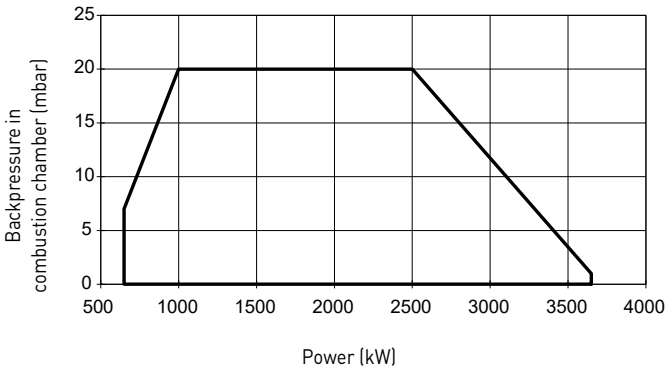

H440X PR-MD

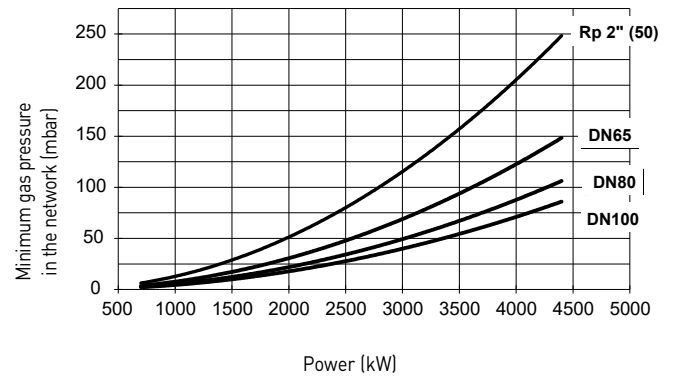
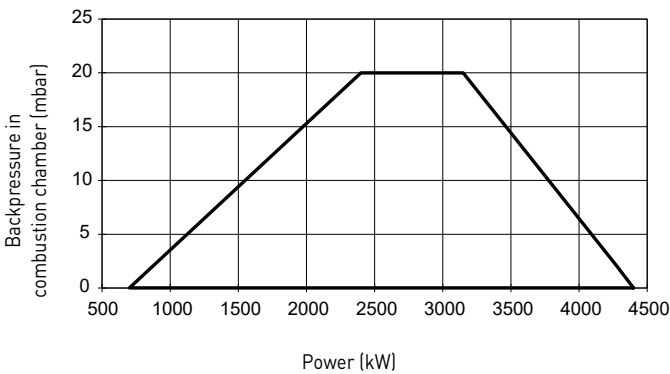

H500X PR-MD

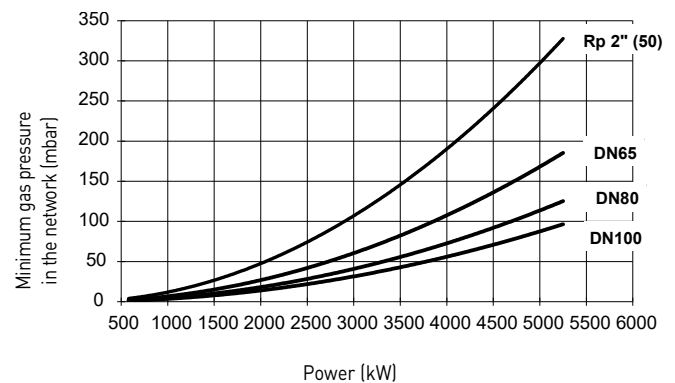
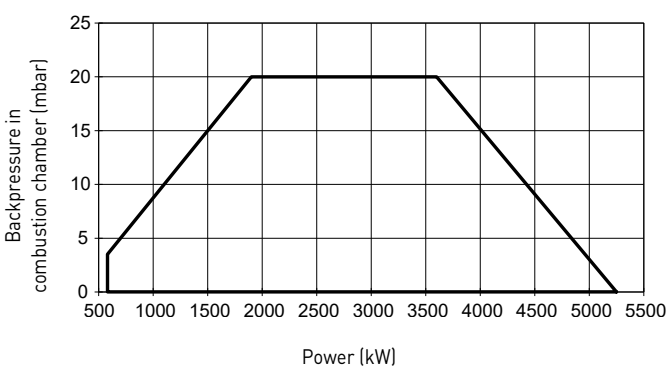

Attention:

- The working range values were determined with reference to laboratory tests with natural gas of lower calorific value $Hi=34.02 \text{ MJ/Stm}^3$ and density 0.714 kg/Stm^3 , (Stm^3 refers to 1013 mbar and 15° C) and ambient conditions 1013 mbar and 20° C .
- To know the minimum gas pressure in the network, it is necessary to add the boiler back pressure to the value read on the curve.
- The pressure values vary depending on the configuration of the gas ramp. The minimum gas pressure curves refer to gas ramps assembled with standard supply valves.
- In the abscissa is the power value, in the ordinate the corresponding network pressure value net of the pressure in the combustion chamber. In order to know the minimum pressure at the ramp inlet, necessary to obtain the required gas flow, the pressure in the combustion chamber must be added to the value read on the ordinate.

HEAD N

H340V
H455V

Ultra Low NOx

Low emissions (Class 4 - EN676)

Wide modulation range

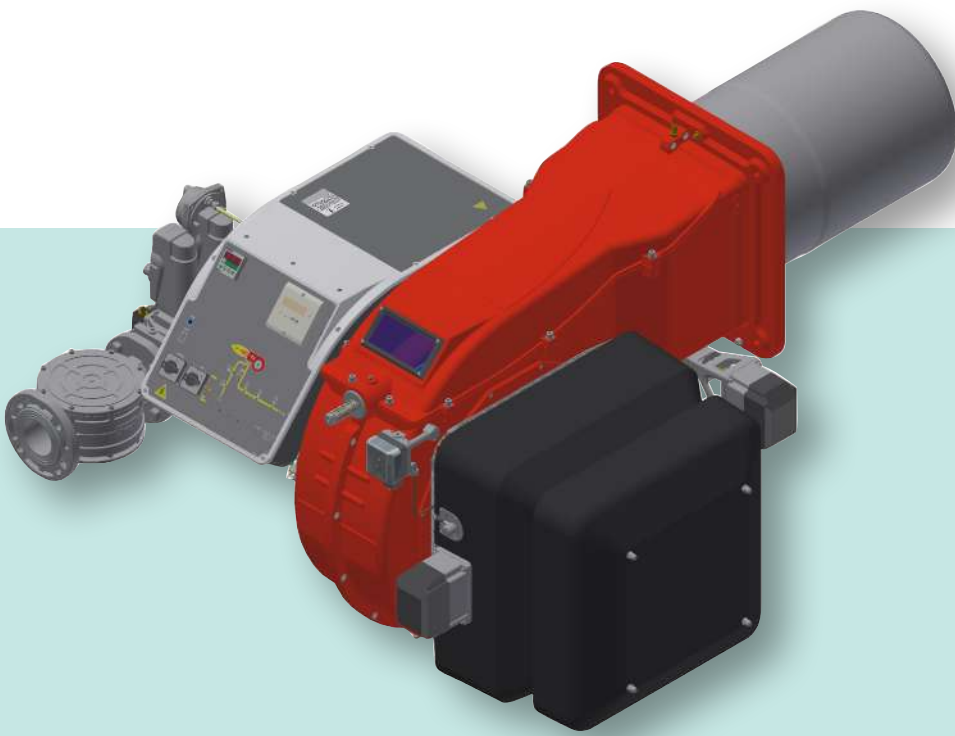

GAS

TECHNICAL SPECIFICATIONS

Type	Model	Power kW		Power supply single-phase electricity auxiliary	Power supply three-phase electric motor	Fan motor kW	Gas connections	Level of noise emissions dBA
		min	max					
H340V	M-.xx.S.IT.A.1.xxx	600	3.400	230 V 1N AC 50 Hz	400 V 3 AC 50 Hz	7,5	2" - DN65 - DN80 - DN100	82,2
H455V	M-.xx.S.IT.A.1.65	750	4.550	230 V 1N AC 50 Hz	400 V 3 AC 50 Hz	7,5	2" - DN65 - DN80 - DN100	85,6

For information on choosing the length of the blast tube, refer to the Technical Information booklet.

DIMENSIONS* (mm)

H340V M-.PR.SR.IT.A.1.65.EA

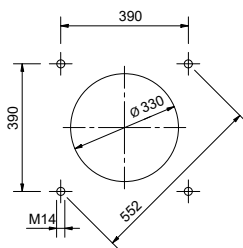
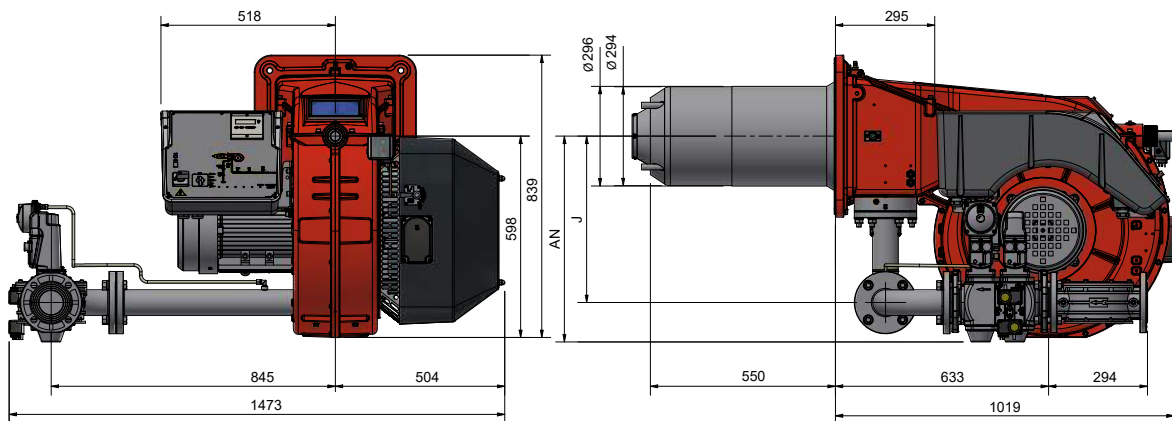

BOILER RECOMMENDED DRILLING TEMPLATE

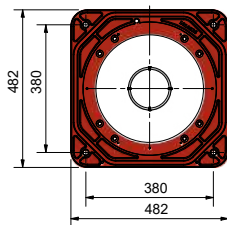

BURNER FLANGE

PACKAGING DIMENSIONS* (mm)

Type	l	p	h	kg
H340V	1890	1290	1220	315
H455V	1890	1290	1220	335

*INDICATIVE VALUES

ELECTRONIC OPERATION

Model	Gas train	Operation
M-.PR.SR.IT.A.1.50.EA	2"	PR (*)
M-.PR.SR.IT.A.1.65.EA	DN65	PR (*)
M-.PR.SR.IT.A.1.80.EA	DN80	PR (*)
M-.PR.SR.IT.A.1.100.EA	DN100	PR (*)
M-.MD.SR.IT.A.1.50.ES	2"	MD
M-.MD.SR.IT.A.1.65.ES	DN65	MD
M-.MD.SR.IT.A.1.80.ES	DN80	MD
M-.MD.SR.IT.A.1.100.ES	DN100	MD

PERFORMANCE CURVES

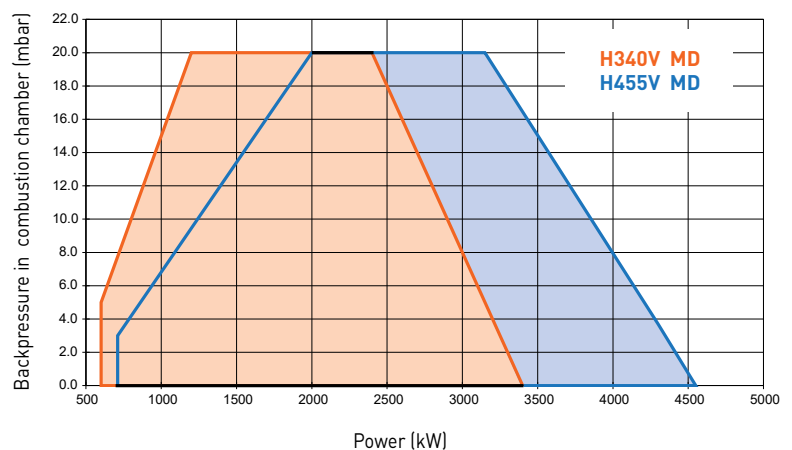

Attention: - The size of the gas train varies according to size and configuration.

- SP = Standard blast tube + aluminum air intake (1)
- SR = Standard blast tube + ABS polymer (silenced) air intake
- LP = Extended blast tube + aluminum air intake
- LR = Extended blast tube + ABS polymer (silenced) air intake (2)
- PR = Progressive Adjustment
- MD (*) = Modulating adjustment
(for the MD modulating version, the Modulation Kit must be added; see the list of variants)

Modulation kit = Kit to be combined with PR Progressive versions

In the MD modulating version, the burner must be equipped with the relevant modulating probe to complete the supply.

For LPG burners, see the list of variants

(1) For applications on furnaces and rotary drums, see the version with aluminium drawer (SP). Contact Cib Unigas for any clarification.

(2) For the following versions, please contact our offices.

The products comply with European standards EN676 and EN267 and the following directives:
DIRECTIVE GAR 2016/426/EU

NOx emission level:
- Class 4 (<60 mg/kWh) in gas operation according to EN676

For information on choosing the length of the blast tube, refer to the Technical Information booklet.



Burners also compatible with GPL, H₂

PERFORMANCE CURVES

PRESSURE IN THE NETWORK

H340V

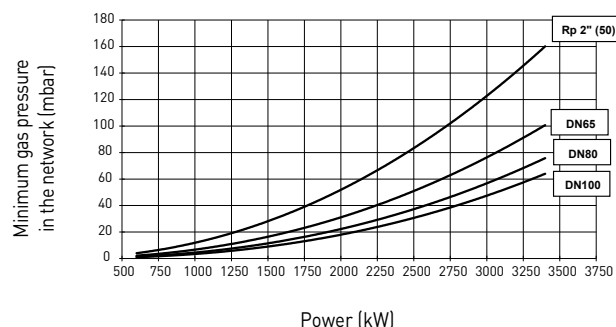
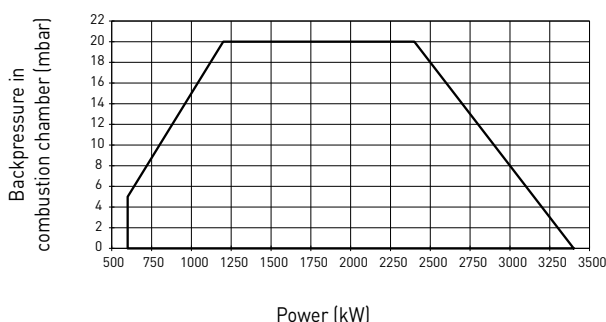

H455V

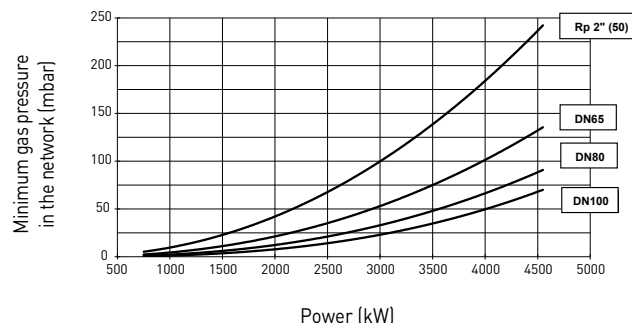
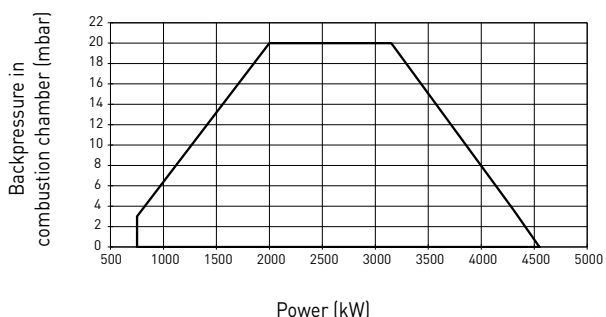

- Attention:**
- The working range values were determined with reference to laboratory tests with natural gas of lower calorific value $Hi=34.02 \text{ MJ/Stm}^3$ and density 0.714 kg/Stm^3 , (Stm^3 refers to 1013 mbar and 15° C) and ambient conditions 1013 mbar and 20° C .
 - To know the minimum gas pressure in the network, it is necessary to add the boiler back pressure to the value read on the curve.
 - The pressure values vary depending on the configuration of the gas ramp. The minimum gas pressure curves refer to gas ramps assembled with standard supply valves.
 - In the abscissa is the power value, in the ordinate the corresponding network pressure value net of the pressure in the combustion chamber. In order to know the minimum pressure at the ramp inlet, necessary to obtain the required gas flow, the pressure in the combustion chamber must be added to the value read on the ordinate.

Highly flexible burners

HEAD A

H455A

H630A

H685A

- Extensive flexibility
- Adjustment flexibility
- Possibility of working with all types of vacuum furnaces
- Many types of civil and industrial applications

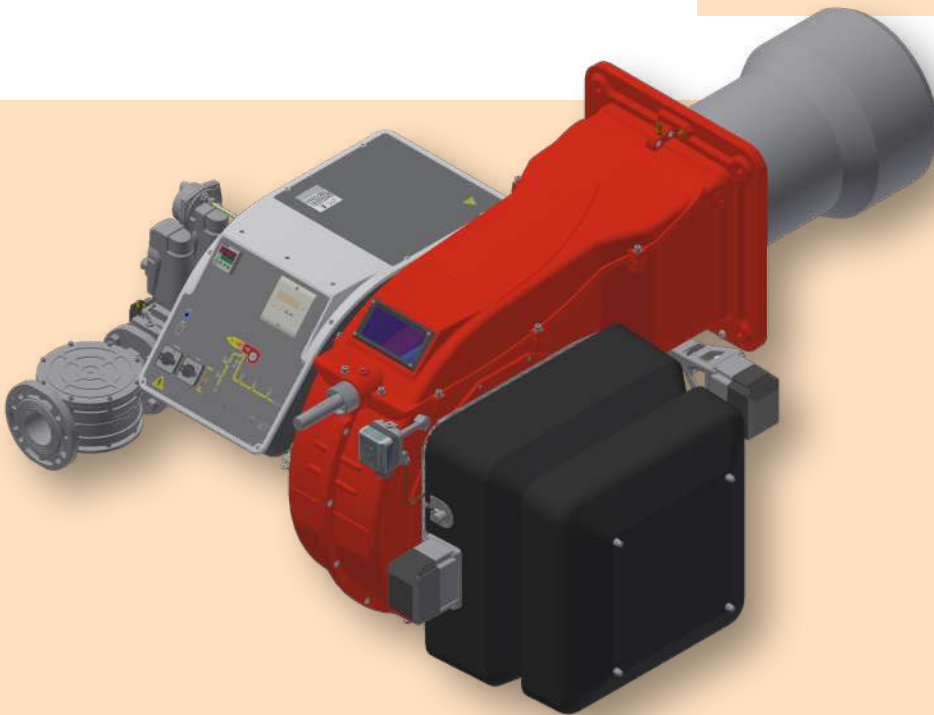

GAS

TECHNICAL SPECIFICATIONS

Type	Model	Power kW		Power supply single-phase electricity auxiliary	Power supply three-phase electric motor	Fan motor kW	Gas connections	Level of noise emissions dBA
		min	max					
H455A	M-.xx.SR.IT.A.1.xxx	750	4.550	230 V 1N AC 50 Hz	400 V 3 AC 50 Hz	7,5	2" - DN65 - DN80 - DN100	< 85
H630A	M-.xx.SR.IT.A.1.xxx	700	6.300	230 V 1N AC 50 Hz	400 V 3 AC 50 Hz	9,2	2" - DN65 - DN80 - DN100	< 85
H685A	M-.xx.SR.IT.A.1.xxx	740	6.850	230 V 1N AC 50 Hz	400 V 3 AC 50 Hz	9,2	2" - DN65 - DN80 - DN100	< 85

For information on choosing the length of the blast tube, refer to the Technical Information booklet.

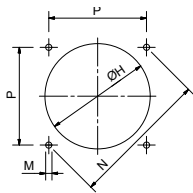
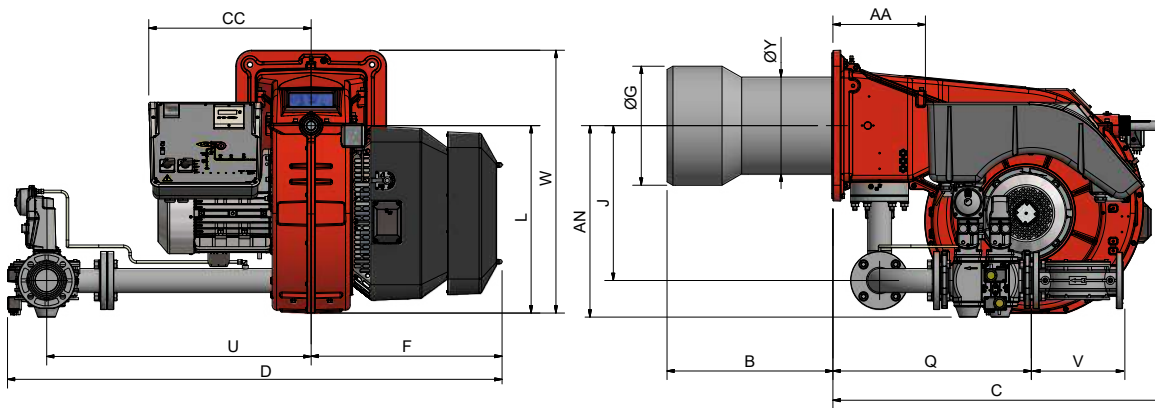

BOILER RECOMMENDED DRILLING TEMPLATE

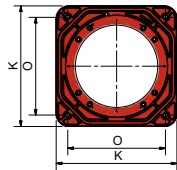

BURNER FLANGE

PACKAGING DIMENSIONS* (mm)

Type	l	p	h	kg
H455A	1890	1290	1220	378
H630A	1890	1290	1220	380
H685A	1890	1290	1220	385

* INDICATIVE VALUES (REFERRED TO THE MODEL WITH DN80 GAS TRAIN)

DIMENSIONS* (mm)

Type	Model	Overall dimensions																				
		AA	AN	B	C	CC	D	F	G	H	J	K	L	M	N	O	P	Q	U	V	W	Y
H455A	M-.xx.SR.IT.A.1.50	295	595	495	1024	528	1561	610	304	346	494	482	598	M14	552	390	390	771	845	190	839	248
H455A	M-.xx.SR.IT.A.1.65	295	611	495	1024	528	1584	610	304	346	494	482	598	M14	552	390	390	634	845	294	839	248
H455A	M-.xx.SR.IT.A.1.80	295	626	495	1024	528	1617	610	304	346	494	482	598	M14	552	390	390	686	875	313	839	248
H455A	M-.xx.SR.IT.A.1.100	295	639	495	1024	528	1697	610	304	346	494	482	598	M14	552	390	390	791	942	353	839	248
H630A	M-.xx.SR.IT.A.1.50	295	595	530	1041	528	1561	610	340	380	494	482	598	M14	552	390	390	771	845	190	839	284
H630A	M-.xx.SR.IT.A.1.65	295	611	530	1041	528	1584	610	340	380	494	482	598	M14	552	390	390	634	845	294	839	284
H630A	M-.xx.SR.IT.A.1.80	295	626	530	1041	528	1617	610	340	380	494	482	598	M14	552	390	390	686	875	313	839	284
H630A	M-.xx.SR.IT.A.1.100	295	639	530	1041	528	1697	610	340	380	494	482	598	M14	552	390	390	791	942	353	839	284
H685A	M-.xx.SR.IT.A.1.50	295	595	530	1057	528	1561	610	380	410	494	482	598	M14	552	390	390	771	845	190	839	310
H685A	M-.xx.SR.IT.A.1.65	295	611	530	1057	528	1584	610	380	410	494	482	598	M14	552	390	390	634	845	294	839	310
H685A	M-.xx.SR.IT.A.1.80	295	626	530	1057	528	1617	610	380	410	494	482	598	M14	552	390	390	686	875	313	839	310
H685A	M-.xx.SR.IT.A.1.100	295	639	530	1057	528	1697	610	380	410	494	482	598	M14	552	390	390	791	942	353	839	310

*INDICATIVE VALUES

Attention: - The size of the gas train varies according to size and configuration.

MECHANICAL OPERATION

Model	Gas train	Operation
M-.PR.SR.IT.A.1.50	2"	PR (*)
M-.PR.SR.IT.A.1.65	DN65	PR (*)
M-.PR.SR.IT.A.1.80	DN80	PR (*)
M-.PR.SR.IT.A.1.100	DN100	PR (*)

ELECTRONIC OPERATION

Model	Gas train	Operation
M-.PR.SR.IT.A.1.50.EA	2"	PR (*)
M-.PR.SR.IT.A.1.65.EA	DN65	PR (*)
M-.PR.SR.IT.A.1.80.EA	DN80	PR (*)
M-.PR.SR.IT.A.1.100.EA	DN100	PR (*)
M-.MD.SR.IT.A.1.50.ES	2"	MD
M-.MD.SR.IT.A.1.65.ES	DN65	MD
M-.MD.SR.IT.A.1.80.ES	DN80	MD
M-.MD.SR.IT.A.1.100.ES	DN100	MD

SP = Standard blast tube + aluminum air intake (1)
 SR = Standard blast tube + ABS polymer (silenced) air intake
 LP = Extended blast tube + aluminum air intake
 LR = Extended blast tube + ABS polymer (silenced) air intake (2)
 PR = Progressive Adjustment
 MD (*) = Modulating adjustment
 (for the MD modulating version, the Modulation Kit must be added; see the list of variants)

Modulation kit = Kit to be combined with PR Progressive versions

In the MD modulating version, the burner must be equipped with the relevant modulating probe to complete the supply.

For LPG burners, see the list of variants

(1) For applications on furnaces and rotary drums, see the version with aluminium drawer (SP). Contact Cib Unigas for any clarification.

(2) For the following versions, please contact our offices.

The products comply with European standards EN676 and EN267 and the following directives:
 DIRECTIVE GAR 2016/426/EU

NOx emission level:
 - Class 2 (<120 mg/kWh) in gas operation according to EN676

For information on choosing the length of the blast tube, refer to the Technical Information booklet.



Burners also compatible with GPL, biogas, syngas, off gas

PERFORMANCE CURVES

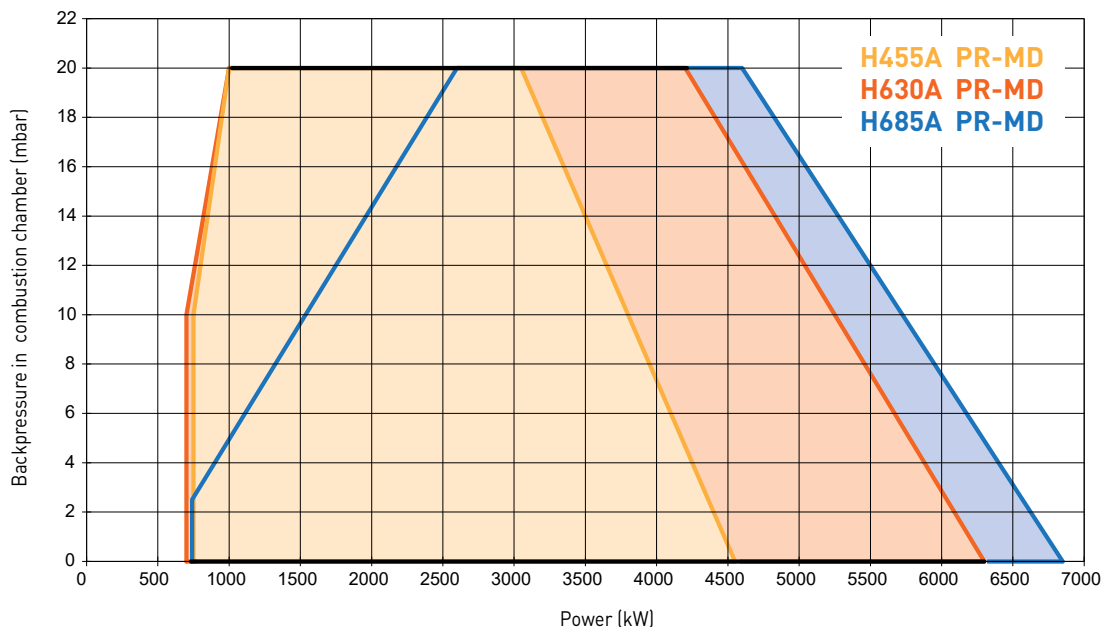

PERFORMANCE CURVES

PRESSURE IN THE NETWORK

H455A PR-MD

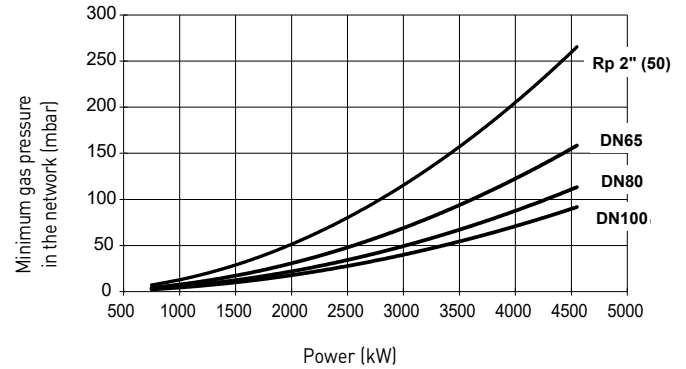
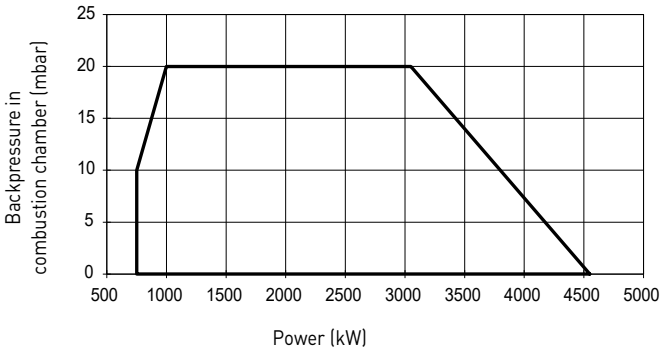

H630A PR-MD

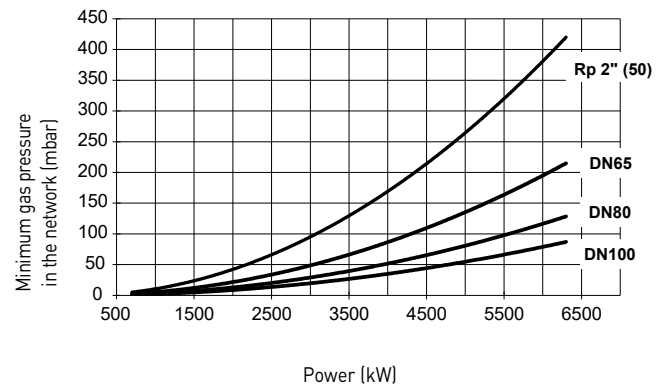
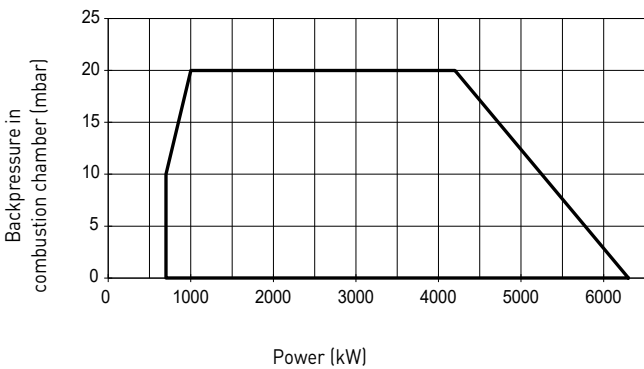

H685A PR-MD

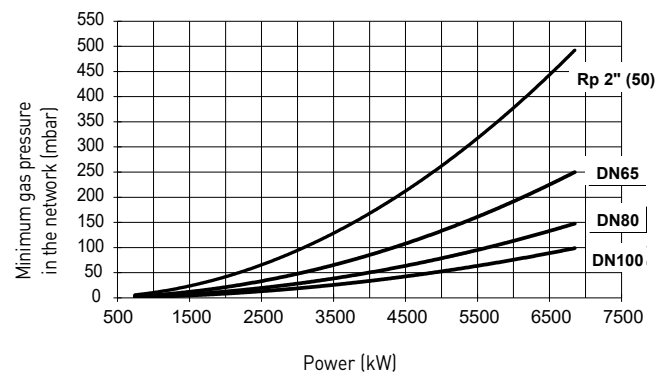
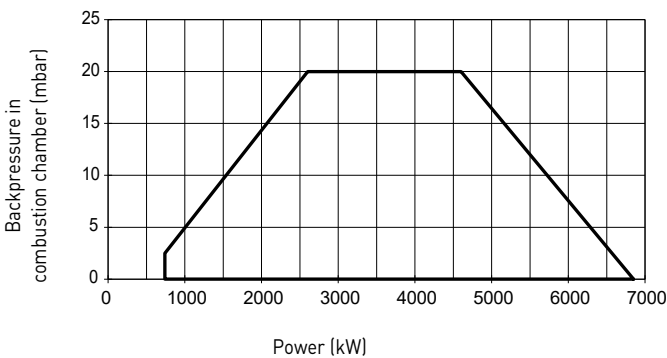

Attention:

- The working range values were determined with reference to laboratory tests with natural gas of lower calorific value $Hi=34.02 \text{ MJ/Stm}^3$ and density 0.714 kg/Stm^3 , (Stm^3 refers to 1013 mbar and 15° C) and ambient conditions 1013 mbar and 20° C .
- To know the minimum gas pressure in the network, it is necessary to add the boiler back pressure to the value read on the curve.
- The pressure values vary depending on the configuration of the gas ramp. The minimum gas pressure curves refer to gas ramps assembled with standard supply valves.
- In the abscissa is the power value, in the ordinate the corresponding network pressure value net of the pressure in the combustion chamber. In order to know the minimum pressure at the ramp inlet, necessary to obtain the required gas flow, the pressure in the combustion chamber must be added to the value read on the ordinate.

Highly flexible burners

HEAD A

H455A
H630A
H685A

- Extensive flexibility
- Adjustment flexibility
- Possibility of working with all types of vacuum furnaces
- Many types of civil and industrial applications

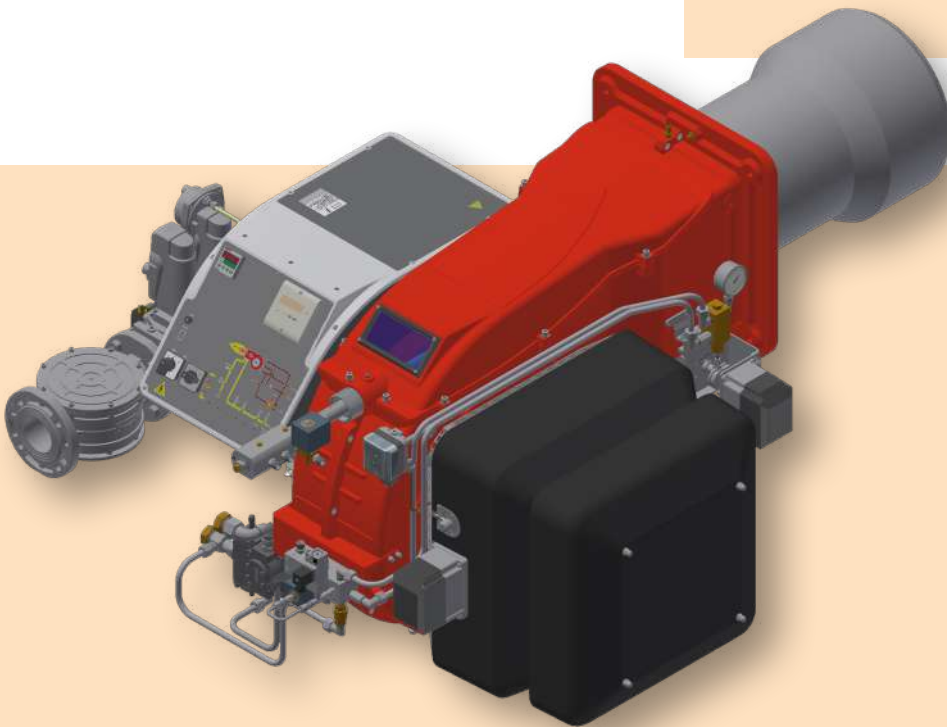

GAS / LIGHT OIL

TECHNICAL SPECIFICATIONS

Type	Model	Power kW		Power supply single-phase electricity auxiliary	Power supply three-phase electric motor	Fan motor kW	Pump motor kW	Gas connections	Level of noise emissions dBA
		min	max						
H455A	MG.xx.SR.IT.A.1.xxx	750	4.550	230 V 1N AC 50 Hz	400 V 3 AC 50 Hz	7,5	1,1	2" - DN65 - DN80 - DN100	< 85
H630A	MG.xx.SR.IT.A.1.xxx	700	6.300	230 V 1N AC 50 Hz	400 V 3 AC 50 Hz	9,2	1,5	2" - DN65 - DN80 - DN100	< 85
H685A	MG.xx.SR.IT.A.1.xxx	740	6.850	230 V 1N AC 50 Hz	400 V 3 AC 50 Hz	9,2	1,5	2" - DN65 - DN80 - DN100	< 85

For information on choosing the length of the blast tube, refer to the Technical Information booklet.

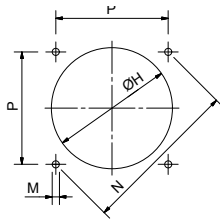
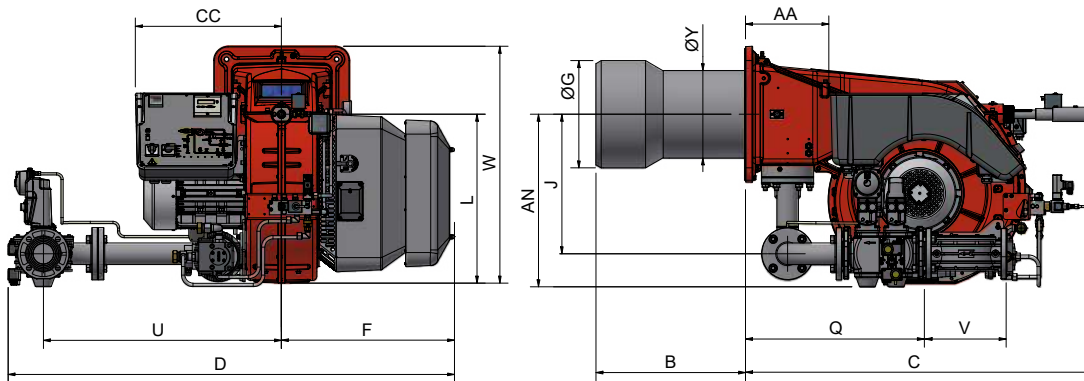

BOILER RECOMMENDED DRILLING TEMPLATE

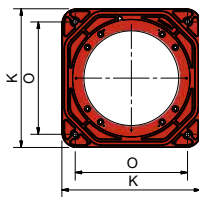

BURNER FLANGE



PACKAGING DIMENSIONS* (mm)

Type	l	p	h	kg
H455A	1890	1290	1220	390
H630A	1890	1290	1220	420
H685A	1890	1290	1220	430

* INDICATIVE VALUES (REFERRED TO THE MODEL WITH DN80 GAS TRAIN)

DIMENSIONS* (mm)

Type	Model	Overall dimensions																				
		AA	AN	B	C	CC	D	F	G	H	J	K	L	M	N	O	P	Q	U	V	W	Y
H455A	MG.xx.SR.IT.A.1.50	295	595	495	1233	528	1554	610	304	344	494	482	598	M14	552	390	390	771	845	190	839	248
H455A	MG.xx.SR.IT.A.1.65	295	611	495	1233	528	1577	610	304	344	494	482	598	M14	552	390	390	634	845	294	839	248
H455A	MG.xx.SR.IT.A.1.80	295	626	495	1233	528	1610	610	304	344	494	482	598	M14	552	390	390	686	875	313	839	248
H455A	MG.xx.SR.IT.A.1.100	295	639	495	1233	528	1690	610	304	344	494	482	598	M14	552	390	390	791	942	353	839	248
H630A	MG.xx.SR.IT.A.1.50	295	595	530	1233	528	1554	610	340	380	494	482	598	M14	552	390	390	771	845	190	839	284
H630A	MG.xx.SR.IT.A.1.65	295	611	530	1233	528	1577	610	340	380	494	482	598	M14	552	390	390	634	845	294	839	284
H630A	MG.xx.SR.IT.A.1.80	295	626	530	1233	528	1610	610	340	380	494	482	598	M14	552	390	390	686	875	313	839	284
H630A	MG.xx.SR.IT.A.1.100	295	639	530	1233	528	1690	610	340	380	494	482	598	M14	552	390	390	791	942	353	839	284
H685A	MG.xx.SR.IT.A.1.50	295	595	530	1233	528	1554	610	380	410	494	482	598	M14	552	390	390	771	845	190	839	310
H685A	MG.xx.SR.IT.A.1.65	295	611	530	1233	528	1577	610	380	410	494	482	598	M14	552	390	390	634	845	294	839	310
H685A	MG.xx.SR.IT.A.1.80	295	626	530	1233	528	1610	610	380	410	494	482	598	M14	552	390	390	686	875	313	839	310
H685A	MG.xx.SR.IT.A.1.100	295	639	530	1233	528	1690	610	380	410	494	482	598	M14	552	390	390	791	942	353	839	310

*INDICATIVE VALUES

Attention: - The size of the gas train varies according to size and configuration.

MECHANICAL OPERATION

Model	Gas train	Operation
MG.PR.SR.IT.A.1.50	2"	PR (*)
MG.PR.SR.IT.A.1.65	DN65	PR (*)
MG.PR.SR.IT.A.1.80	DN80	PR (*)
MG.PR.SR.IT.A.1.100	DN100	PR (*)

ELECTRONIC OPERATION

Model	Gas train	Operation
MG.PR.SR.IT.A.1.50.EC	2"	PR (*)
MG.PR.SR.IT.A.1.65.EC	DN65	PR (*)
MG.PR.SR.IT.A.1.80.EC	DN80	PR (*)
MG.PR.SR.IT.A.1.100.EC	DN100	PR (*)
MG.MD.SR.IT.A.1.50.ES	2"	MD
MG.MD.SR.IT.A.1.65.ES	DN65	MD
MG.MD.SR.IT.A.1.80.ES	DN80	MD
MG.MD.SR.IT.A.1.100.ES	DN100	MD

SP = Standard blast tube + aluminum air intake (1)
 SR = Standard blast tube + ABS polymer (silenced) air intake
 LP = Extended blast tube + aluminum air intake
 LR = Extended blast tube + ABS polymer (silenced) air intake (2)
 PR = Progressive Adjustment
 MD (*) = Modulating adjustment
 (for the MD modulating version, the Modulation Kit must be added; see the list of variants)

Modulation kit = Kit to be combined with PR Progressive versions

Nella versione modulante MD per completare la fornitura è necessario corredare il bruciatore della relativa sonda modulante.

For LPG burners, see the list of variants

(1) For applications on furnaces and rotary drums, see the version with aluminium drawer (SP). Contact Cib Unigas for any clarification.

(2) For the following versions, please contact our offices.

The products comply with European standards EN676 and EN267 and the following directives:
 DIRECTIVE GAR 2016/426/EU
 DIRECTIVE Low Tension 2014/35/UE
 DIRECTIVE Electromagnetic compatibility 2014/30/UE
 DIRECTIVE Machinery 2006/42/CE

NOx emission level:

- Class 2 (<120 mg/kWh) in gas operation according to EN676
- Class 1 (< 250 mg/kWh) in light oil operation according to EN267

For information on choosing the length of the blast tube, refer to the Technical Information booklet.



Burners also compatible with GPL, biogas, syngas, off gas, H₂
Burners also compatible with bio-oli

PERFORMANCE CURVES

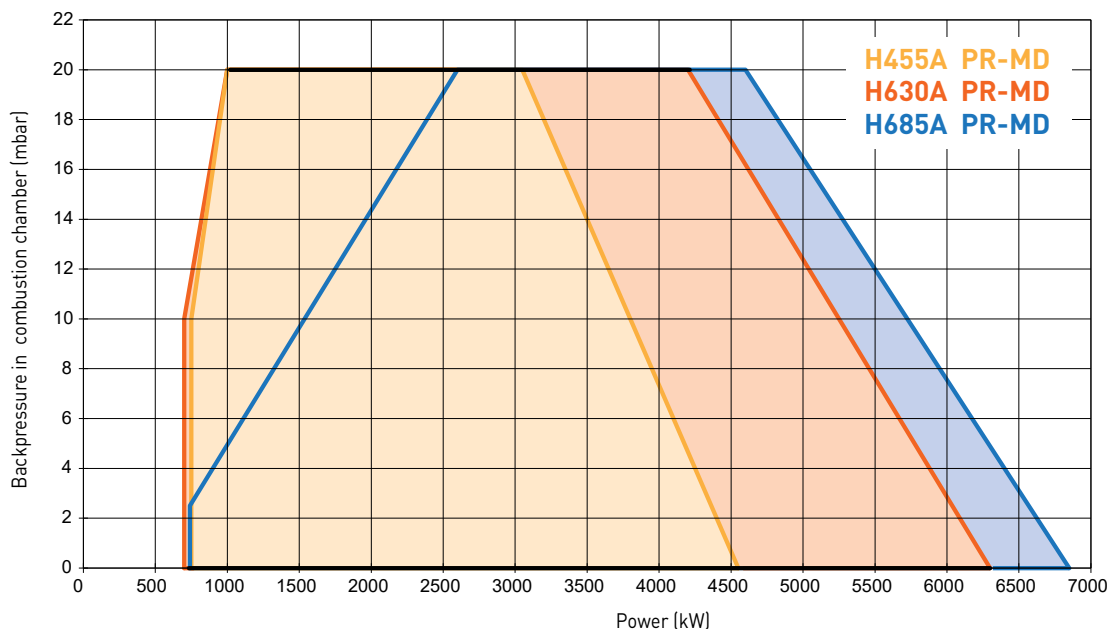

PERFORMANCE CURVES

PRESSURE IN THE NETWORK

H455A PR-MD

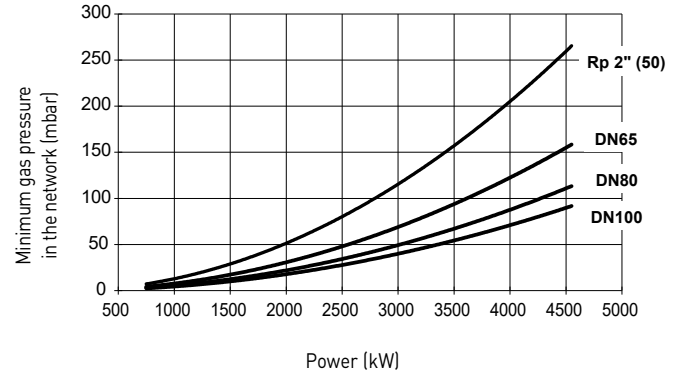
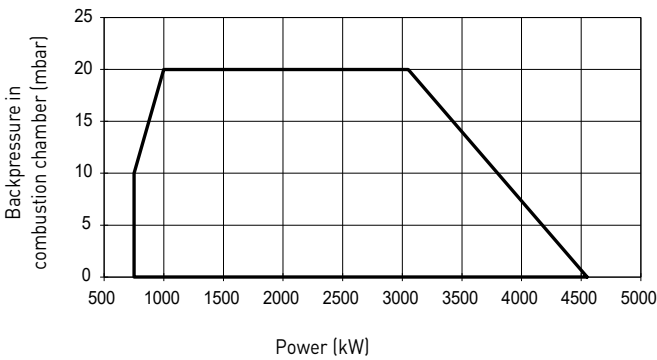

H630A PR-MD

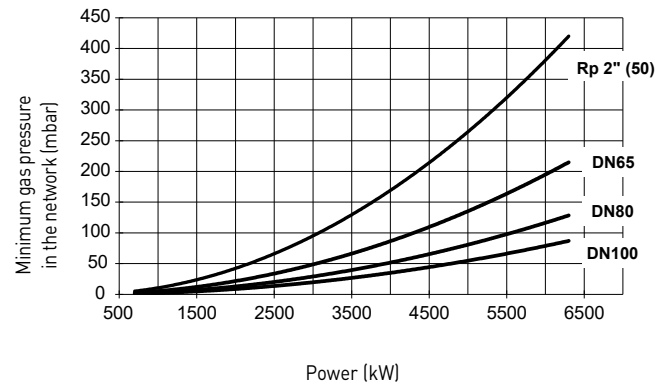
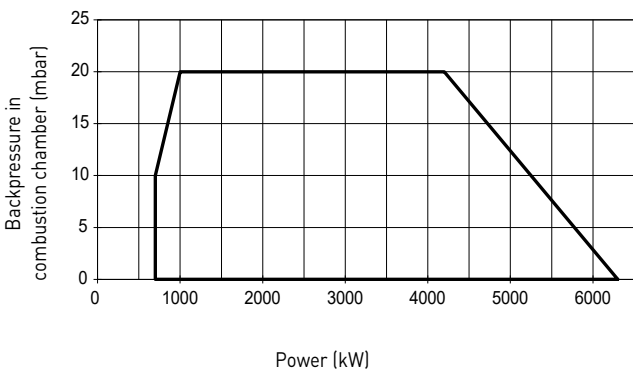

H685A PR-MD

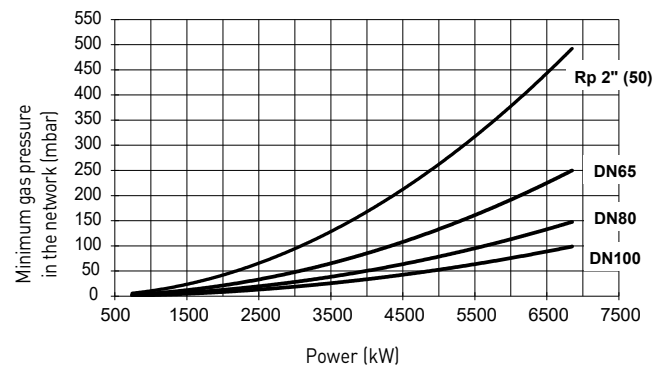
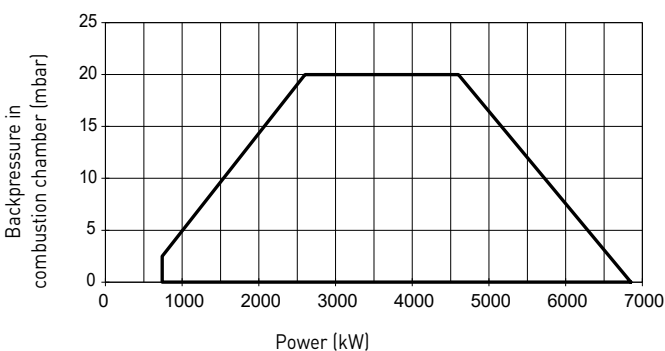

Attention:

- The working range values were determined with reference to laboratory tests with natural gas of lower calorific value $Hi=34.02 \text{ MJ/Stm}^3$ and density 0.714 kg/Stm^3 , (Stm^3 refers to 1013 mbar and 15° C) and ambient conditions 1013 mbar and 20° C .
- To know the minimum gas pressure in the network, it is necessary to add the boiler back pressure to the value read on the curve.
- The pressure values vary depending on the configuration of the gas ramp. The minimum gas pressure curves refer to gas ramps assembled with standard supply valves.
- In the abscissa is the power value, in the ordinate the corresponding network pressure value net of the pressure in the combustion chamber. In order to know the minimum pressure at the ramp inlet, necessary to obtain the required gas flow, the pressure in the combustion chamber must be added to the value read on the ordinate.



C.I.B. UNIGAS S.p.A.

Via L. Galvani, 9 - 35011 CAMPODARSEGO (PD) - Italy

Tel. +39 049 9200944

Fax +39 049 9200945 - 9201269

cibunigas@cibunigas.com - www.cibunigas.com

**Note: specifications and data subject to change.
Errors and omissions excepted.**